

WILIS OPERATIONS

To make getting your feet into/out of the foot stretchers easier, you can use the Temporary Roll Lock feature. Engaging this feature prevents lateral roll when you get on and off the erg.

Operation Questions: 703.969.5773 Row Balance, Inc.

TEMPORARY ROLL LOCK

STEP 1

- A. Before getting on the erg, lift the Roll Lock Handle to the position shown.
- B. Sit on the seat and strap your feet into the footstretchers.

Roll Lock Handle

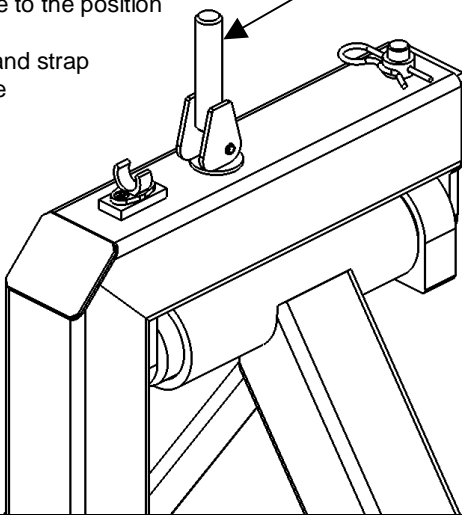

STEP 2

- After your feet are secured, position the Roll Lock Handle into the clip so that the Roll Lock Pin is raised to allow lateral roll.

Roll Lock Pin is raised

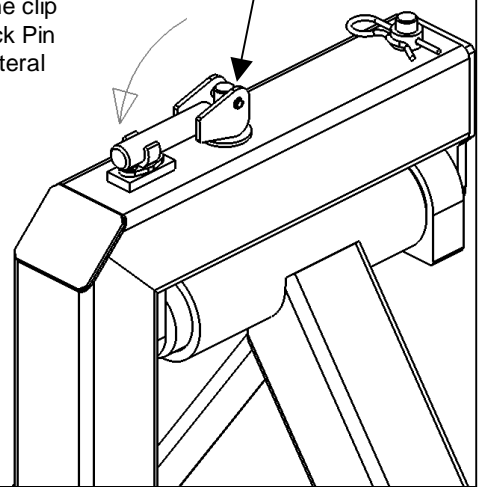

FIXED ROLL LOCK

STEP 1

- Rotate the Roll Lock Handle a half turn as shown.

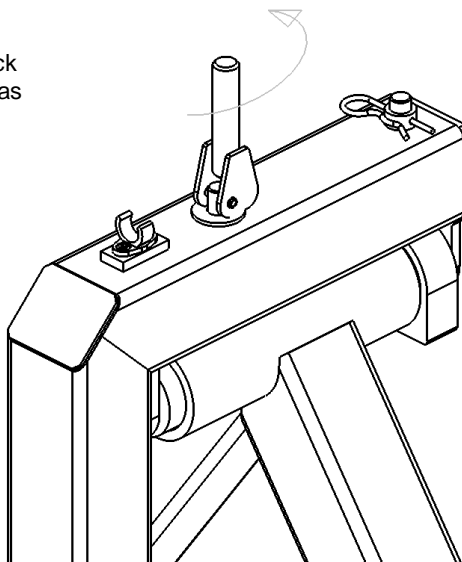

STEP 2

- Position the Roll Lock Handle into the clip.

Roll Lock Pin is lowered

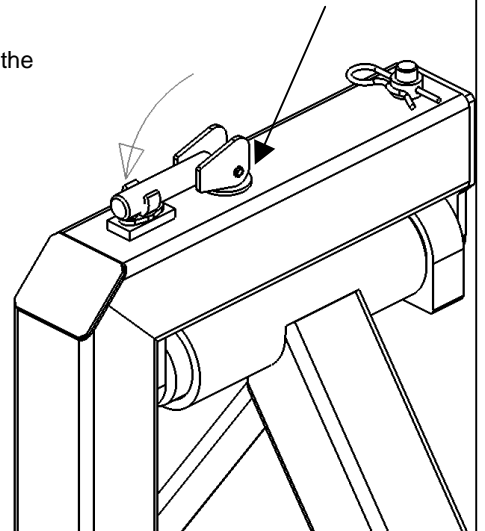

ROLL LIMITER ADJUSTMENT

STEP 1

On the forward Base Frame, remove the Cotter Pin

COTTER PIN

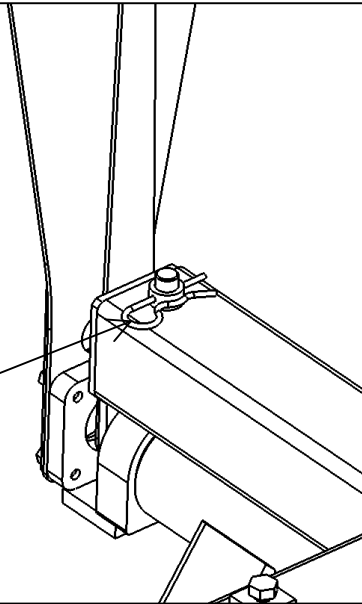

STEP 2

Lift the Roll Limiter Pin as shown

Flats in this position provide +/- 7 degrees of roll

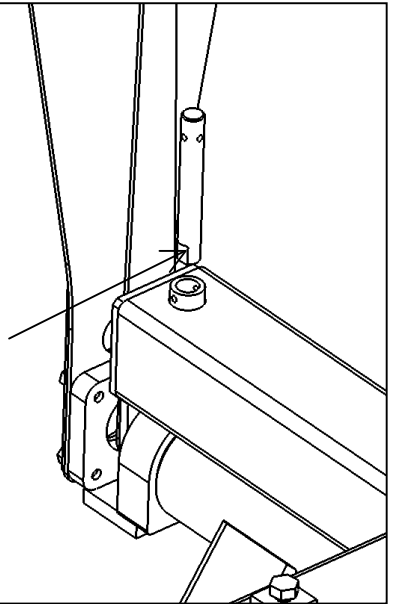

STEP 3

Rotate the Roll Limiter Pin a quarter turn.

Flats in this position provide +/- 4 degrees of roll

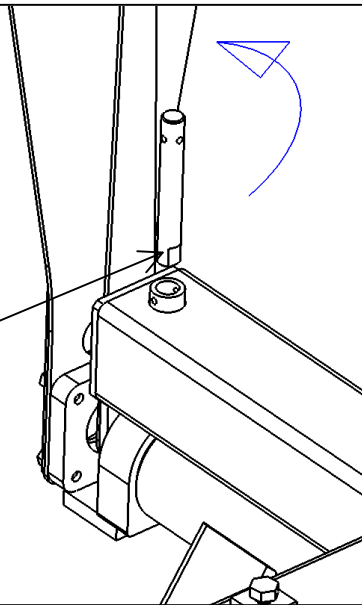

STEP 4

Lower the Roll Limiter Pin

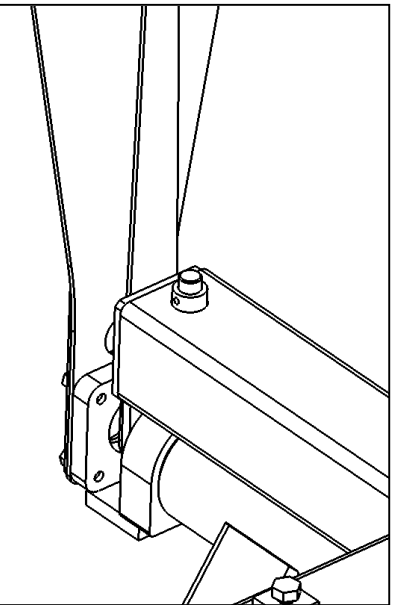

STEP 5

Re-install the Cotter Pin to secure the Roll Limiter Pin in place.

COTTER PIN

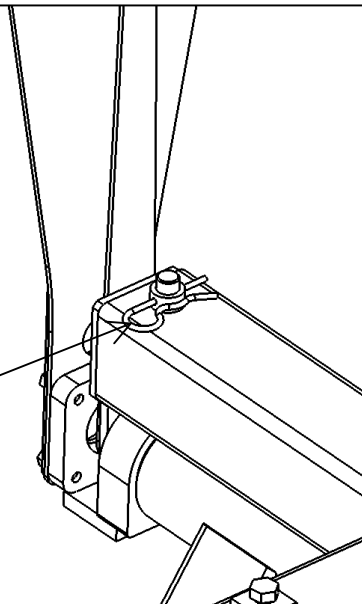

STEP 6

Follow the same procedure on the aft Roll Limiter Pin.

Aft Roll Limiter Pin

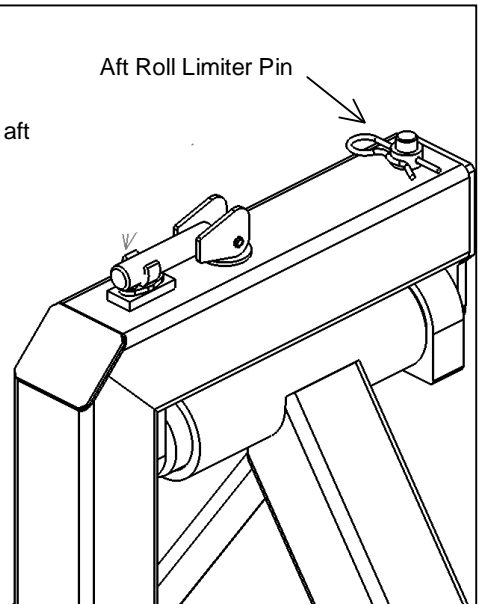

HEIGHT ADJUSTMENT

STEP 1

On the forward end of the erg, pull the Spring Pin and lift the Cradle.

FORWARD
BASE FRAME

FORWARD
CRADLE

SPRING PIN

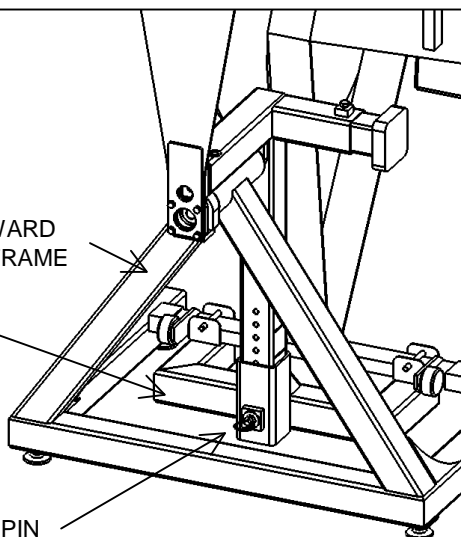

STEP 2

A. Release the Spring Pin near the desired elevation and slide the Cradle up or down until the Spring Pin snaps into the desired hole.

B. Take note of the Elevation Mark on the side of the Swing Arm.

ELEVATION MARKS

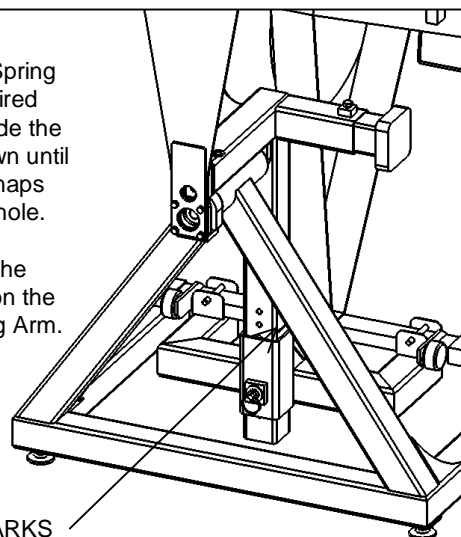

STEP 3

On the aft end of the erg, pull the Spring Pin and lift the Cradle.

AFT BASE FRAME

AFT CRADLE

SPRING PIN

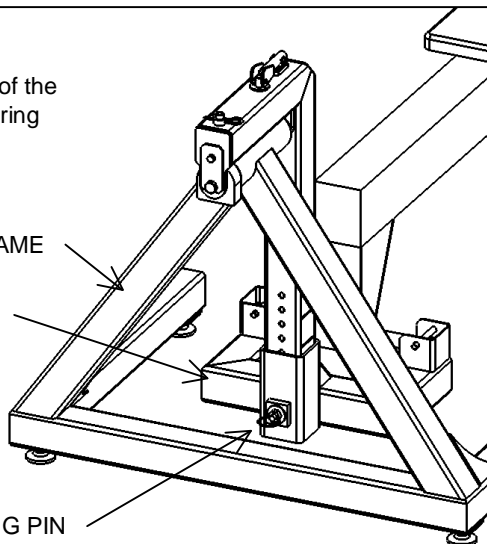

STEP 4

Release the Spring Pin when the elevation is near the Forward Cradle elevation and slide the Cradle up or down until the Spring Pin snaps into the desired hole.

ELEVATION MARKS

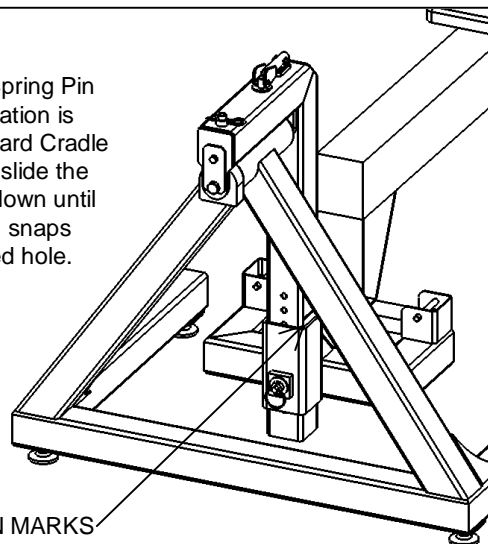

STEP 5

A. Check that the Forward and Aft Cradles are positioned at equivalent Elevation Marks.

B. Adjust if necessary.

